

BURNERS



ALL THERM

OIL, GAS AND DUAL: UP TO 5M KCAL/H
THIRD WORLDWIDE INDUSTRIAL GROUP
TUV INTERNATIONAL CERTIFICACION

2 YEAR GUARANTY

IO 4400
IO 5800



Burner Performance Chart

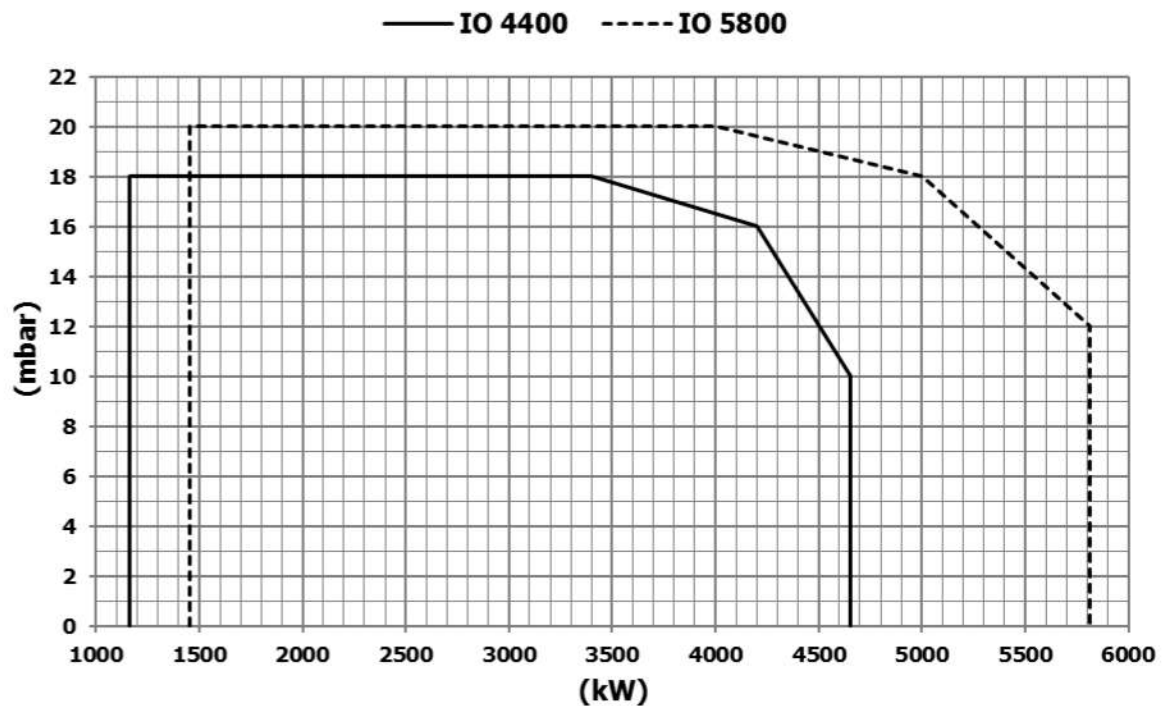

	Function	Fuel	Oil Consumption kg/h	Heating Capacity kW
IO 4400	Modulating	Light Oil	100-400	1163-4651
IO 5800	Modulating	Light Oil	125-500	1453-5814



Burner Dimensions

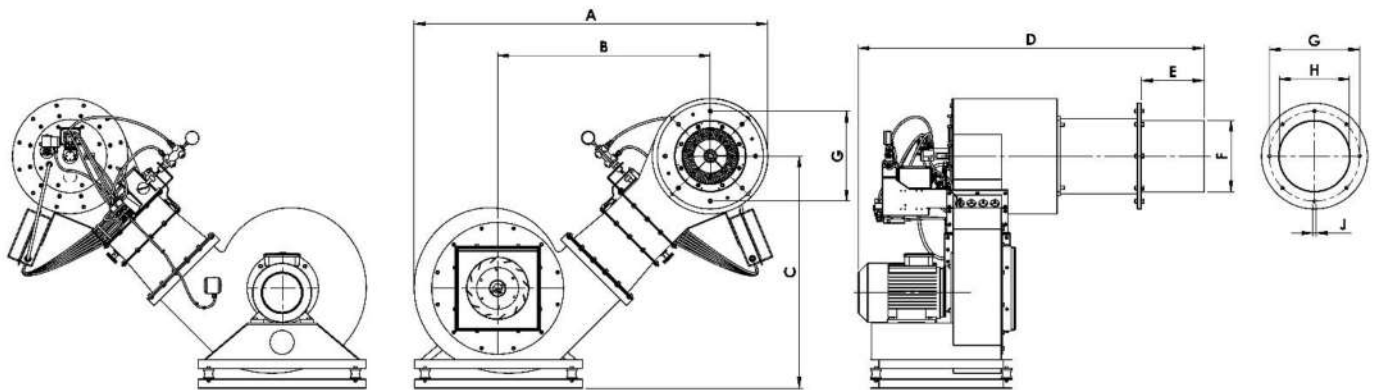

	A	B	C	D	E	F	G	H	J
IO 4400	1570	900	1000	1700	300	340	430	360	M12
IO 5800	1800	1045	1100	1750	300	340	430	360	M12

Burner Equipment	IO 4400	IO 5800
Fan Motor	3 ~ 15 kW	3 ~ 22 kW
Oil Pump Motor	3 ~ 1.5 kW	3 ~ 1.5 kW
Servomotor	Honeywell 9484F	Honeywell 9484F
Control Unit	Satronic TMG 740	Satronic TMG 740
Oil Pump	Suntec TA2A	Suntec TA3A
Ignition Transformer	Brahma T8/G Induction / 2×6.5 kV / 35 mA	Brahma T8/G Induction / 2×6.5 kV / 35 mA
Oil Solenoid Valve	Rapa ¼" SV04R3 Rapa ¼" SV05R3	Rapa ¼" SV04R3 Rapa ¼" SV05R3
Air Pressure Control	Air pressure switch Dungs or Krom schroder	Air pressure switch Dungs or Krom schroder
Flame Detector	Satronic UVZ 780	Satronic UVZ 780
Burner Control Panel	✓ (Separated)	✓ (Separated)



ALL THERM (GIBRALTAR) LTD

HEADQUARTERS :

World Trade Center
6 Bayside Road 1st Floor - Unit 1.02
GX1 1AA Gibraltar
☎ (+350) 200 60207
✉ info@alltherm.group

SALES MANAGER :

Javier *Martinez* Lesmes
C/ López Bravo 7. Naves CAM 45
09001 Burgos
☎ (+34) 639 324 269
✉ j.martinez@alltherm.group

