

BURNERS



ALL THERM

OIL, GAS AND DUAL: UP TO 5M KCAL/H
THIRD WORLDWIDE INDUSTRIAL GROUP
TUV INTERNATIONAL CERTIFICACION

2 YEAR GUARANTY



PGN 1 A
PGN 1 B
PGN 1 C
PGN 1
PGN 1 SP



Burner Performance Chart

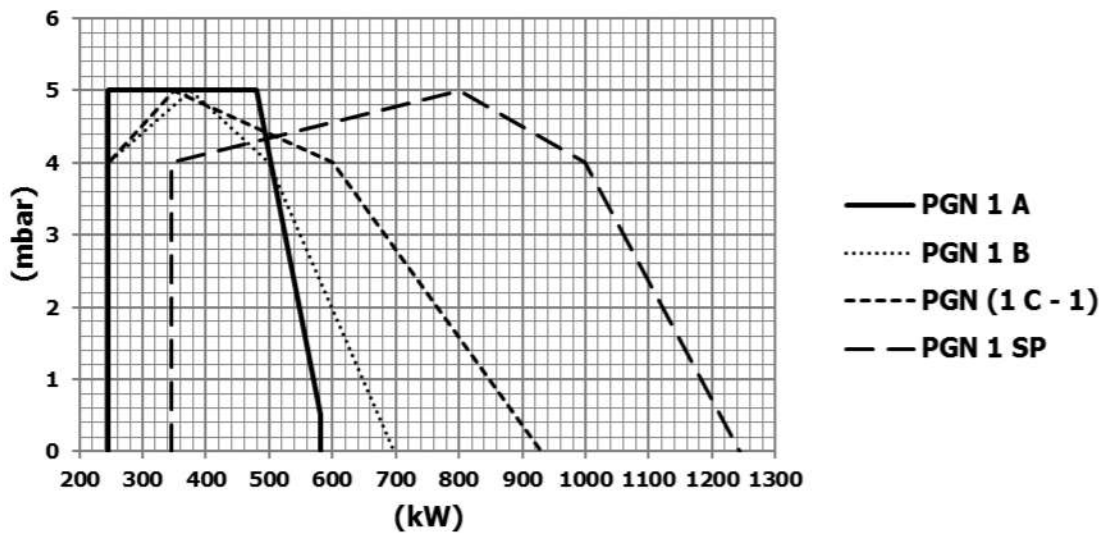

	Function	Fuel	Gas Pressure mbar	Gas Consumption m ³ n/h	Heating Capacity kW
PGN 1 A	Single Stage	Natural Gas	15-60	26-61	246-581
PGN 1 B	Two Stage	Natural Gas	15-60	26-73	246-698
PGN 1 C	Two Stage	Natural Gas	15-60	26-98	246-930
PGN 1	Two Stage	Natural Gas	15-60	26-98	246-930
PGN 1 SP	Two Stage	Natural Gas	22-60	36-130	345-1244



Burner Dimensions (with standard flame tube)

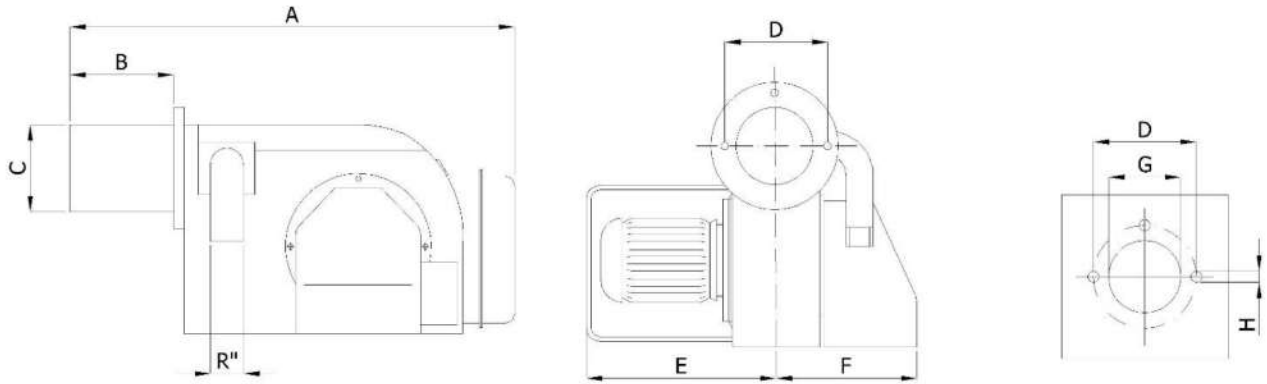

	A	B	C	D	E	F	G	H	R''
PGN 1 A	810	200	165	206	340	370	170	M12	1 ½
PGN 1 B	810	200	165	206	340	370	170	M12	1 ½
PGN 1 C	810	200	165	206	340	440	170	M12	1 ½
PGN 1	810	200	165	206	340	335	170	M12	2
PGN 1 SP	810	200	165	206	340	335	170	M12	2

Burner Dimensions (with long flame tube)

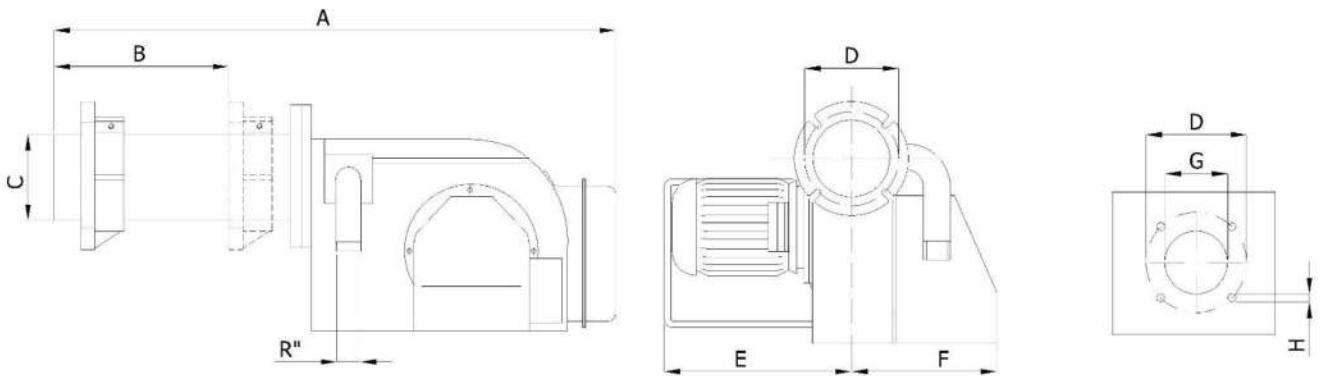

	A	B	C	D	E	F	G	H	R''
PGN 1 A	1040	380	165	205-225	340	370	170	M12	1 ½
PGN 1 B	1040	380	165	205-225	340	370	170	M12	1 ½
PGN 1 C	1040	380	165	205-225	340	440	170	M12	1 ½
PGN 1	1040	380	165	205-225	340	335	170	M12	2
PGN 1 SP	1040	380	165	205-225	340	335	170	M12	2



Burner Equipment	PGN 1 A	PGN 1 B	PGN 1 C
Fan Motor	3 ~ 1.1 kW	3 ~ 1.1 kW	3 ~ 1.1 kW
Servomotor	-	Conectron LKS 160	Conectron LKS 160
Control Unit	G 790	G 790	Satronic DLG 976
Ignition Transformer	Brahma TB2S Electronic / 2×12 kV / 35 mA	Brahma TB2S Electronic / 2×12 kV / 35 mA	Brahma TB2S Electronic / 2×12 kV / 35 mA
Gas Solenoid Valve (Fast Opening)	-	-	Krom Schroder 1 ½"
Gas Solenoid Valve (Slow Opening)	Dungs or Krom Schroder 1 ½"	Dungs 1 ½" 2 Stage	Krom Schroder 1"
Gas Pressure Control	Gas pressure switch Dungs or Krom Schroder	Gas pressure switch Dungs or Krom Schroder	Gas pressure switch Dungs or Krom Schroder
Air Pressure Control	Air pressure switch Dungs or Krom Schroder	Air pressure switch Dungs or Krom Schroder	Air pressure switch Dungs or Krom Schroder
Flame Detector	Ionizing electrode	Ionizing electrode	Ionizing electrode

Burner Equipment	PGN 1	PGN 1 SP
Fan Motor	3 ~ 1.5 kW	3 ~ 1.5 kW
Servomotor	Conectron LKS 160	Conectron LKS 160
Control Unit	Satronic TMG 740	Satronic TMG 740
Ignition Transformer	Brahma TB2S Electronic / 2×12 kV / 35 mA	Brahma TB2S Electronic / 2×12 kV / 35 mA
Gas Solenoid Valve (Fast Opening)	Dungs 1 ½"	Dungs 2"
Gas Solenoid Valve (Slow Opening)	Dungs 1 ½" 2 Stage	Dungs 2" 2 Stage
Gas Pressure Control	Gas pressure switch Dungs or Krom Schroder	Gas pressure switch Dungs or Krom Schroder
Air Pressure Control	Air pressure switch Dungs or Krom Schroder	Air pressure switch Dungs or Krom Schroder
Flame Detector	Ionizing electrode	Ionizing electrode
Burner Control Panel	✓ (Separated)	✓ (Separated)



ALL THERM (GIBRALTAR) LTD

HEADQUARTERS :

World Trade Center
6 Bayside Road 1st Floor - Unit 1.02
GX1 1AA Gibraltar
☎ (+350) 200 60207
✉ info@alltherm.group

SALES MANAGER :

Javier *Martinez* Lesmes
C/ López Bravo 7. Naves CAM 45
09001 Burgos
☎ (+34) 639 324 269
✉ j.martinez@alltherm.group

