

BURNERS



ALL THERM

OIL, GAS AND DUAL: UP TO 5M KCAL/H
THIRD WORLDWIDE INDUSTRIAL GROUP
TUV INTERNATIONAL CERTIFICACION

2 YEAR GUARANTY



RAN 25



Burner Performance Chart

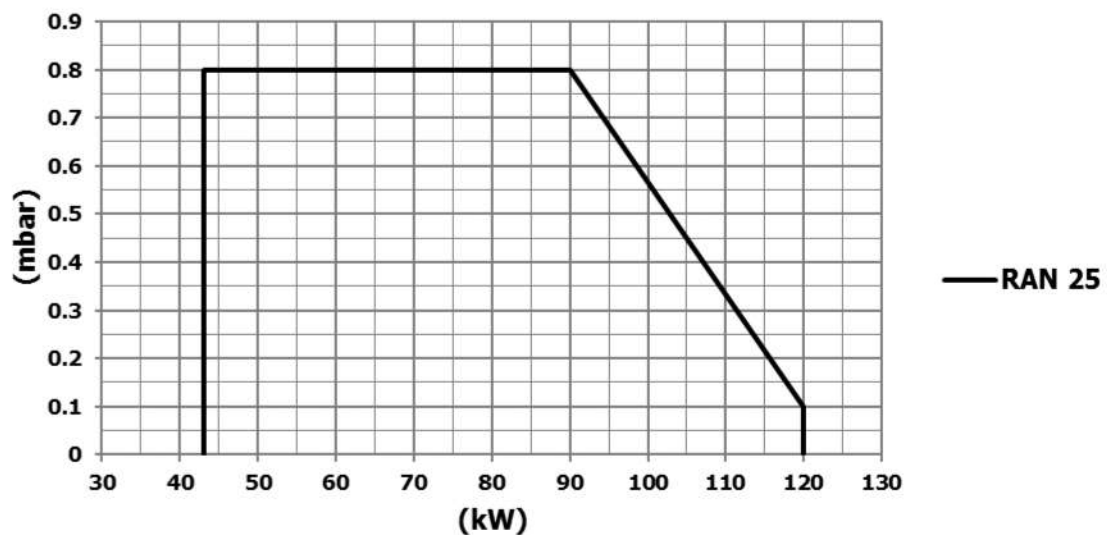

	Function	Fuel	Gas Pressure mbar	Gas Consumption m ³ n/h	Heating Capacity kW
RAN 25	Single Stage	Natural Gas	15-40	4.5-12.5	43-120



Burner Dimensions (with standard flame tube)

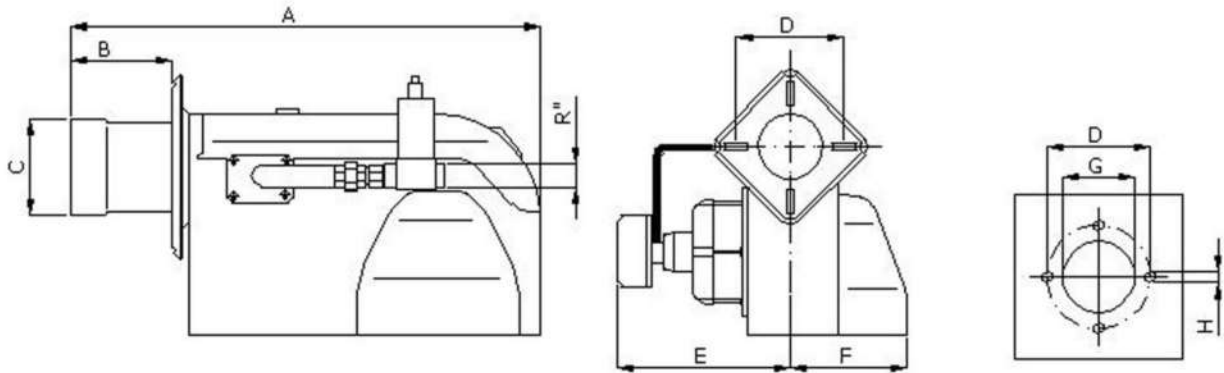

	A	B	C	D	E	F	G	H	R''
RAN 25	417	97	87	120 - 165	213	240	90	M8	1/2

Burner Dimensions (with long flame tube)

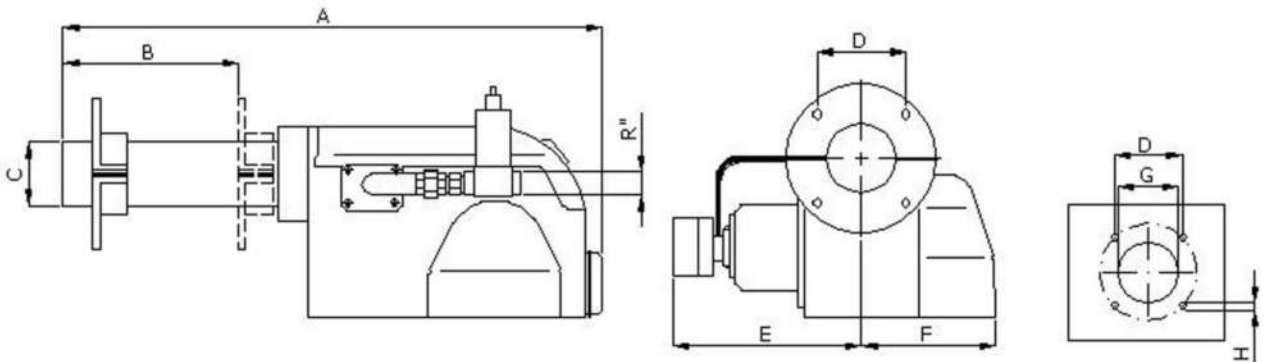

	A	B	C	D	E	F	G	H	R''
RAN 25	780	300	92	117	213	240	100	M8	1/2

Burner Equipment

RAN 25

Fan Motor	1 ~ 90 W
Control Unit	G 790
Ignition Transformer	Electronic/1×10 kV/35 mA
Gas Solenoid Valve (Slow Opening)	Dungs or Krom Schroder 1/2"
Gas Pressure Control	Gas pressure switch Dungs or Krom Schroder
Air Pressure Control	Air pressure switch Dungs or Krom Schroder
Flame Detector	Ionizing electrode



ALL THERM (GIBRALTAR) LTD

HEADQUARTERS :

World Trade Center
6 Bayside Road 1st Floor - Unit 1.02
GX1 1AA Gibraltar
☎ (+350) 200 60207
✉ info@alltherm.group

SALES MANAGER :

Javier *Martinez* Lesmes
C/ López Bravo 7. Naves CAM 45
09001 Burgos
☎ (+34) 639 324 269
✉ j.martinez@alltherm.group

