

BURNERS



ALL THERM

OIL, GAS AND DUAL: UP TO 5M KCAL/H
THIRD WORLDWIDE INDUSTRIAL GROUP
TUV INTERNATIONAL CERTIFICACION

2 YEAR GUARANTY



DJ 2



Burner Performance Chart

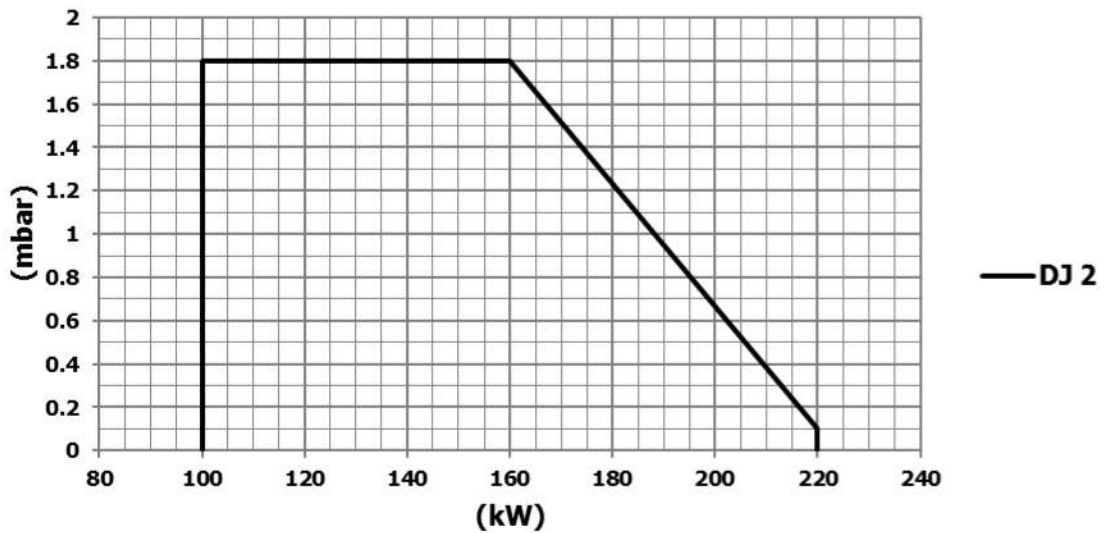

Function	Fuel	Gas Pressure mbar	Gas Consumption m ³ n/h	Oil Consumption kg/h	Heating Capacity kW
DJ 2	Natural Gas/Light Oil	15-40	10.5-23.2	8.6-19	100-220



Burner Dimensions

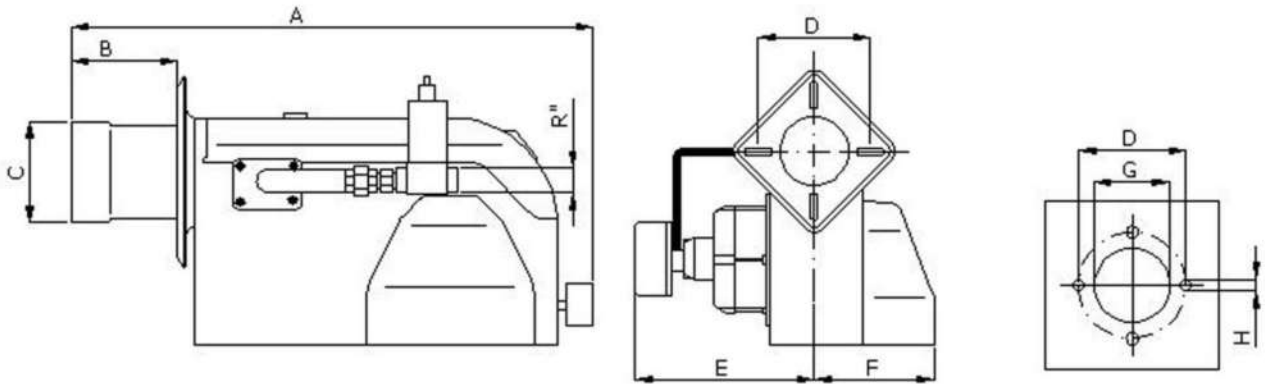

	A	B	C	D	E	F	G	H	R"
DJ 2	652	178	110	173-195	240	295	115	M8	1

Burner Equipment	DJ 2
Fan Motor	1 ~ 240 W
Control Unit	G 811
Oil Pump	Suntec AS47C
Ignition Transformer	Electronic / 2x7 kV / 35 mA
Gas Solenoid Valve (Slow Opening)	Dungs or Krom Schroder 1"
Oil Solenoid Valve	1/8" (With pump)
Gas Pressure Control	Gas pressure switch Dungs or Krom Schroder
Air Pressure Control	Air pressure switch Dungs or Krom Schroder
Flame Detector	Landis QRA2



ALL THERM (GIBRALTAR) LTD

HEADQUARTERS :

World Trade Center
6 Bayside Road 1st Floor - Unit 1.02
GX1 1AA Gibraltar
☎ (+350) 200 60207
✉ info@alltherm.group

SALES MANAGER :

Javier *Martinez* Lesmes
C/ López Bravo 7. Naves CAM 45
09001 Burgos
☎ (+34) 639 324 269
✉ j.martinez@alltherm.group

