

# BURNERS



# ALL THERM

OIL, GAS AND DUAL: UP TO 5M KCAL/H  
THIRD WORLDWIDE INDUSTRIAL GROUP  
TUV INTERNATIONAL CERTIFICACION

**2 YEAR GUARANTY**

**DP 2 A**  
**DP 2**  
**DP 2 SP**



**Burner Performance Chart**

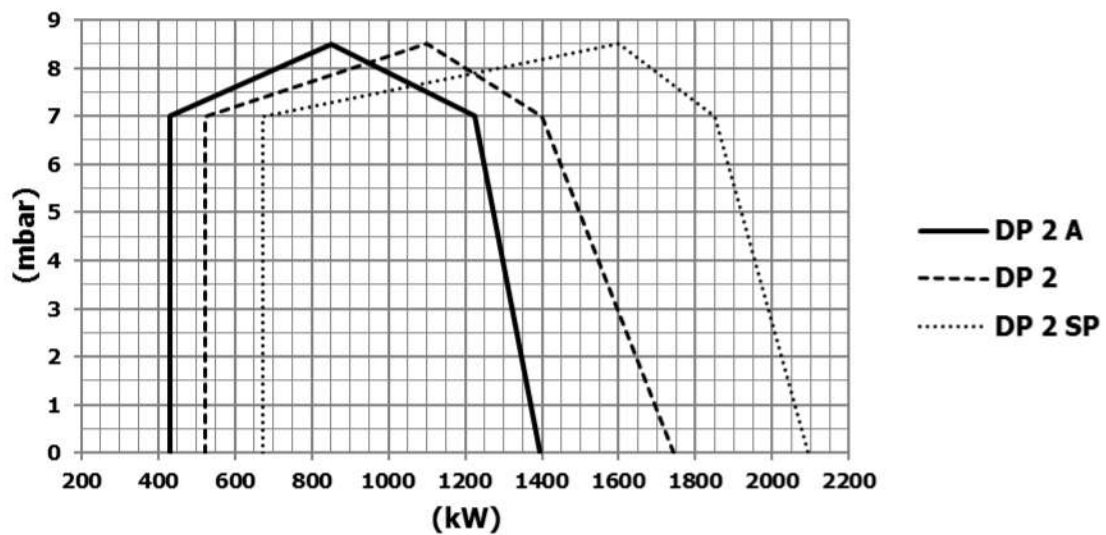

	Function	Fuel	Gas Pressure mbar	Gas Consumption m <sup>3</sup> n/h	Oil Consumption kg/h	Heating Capacity kW
<b>DP 2 A</b>	Two Stage	Natural Gas/Light Oil	40-80	45-147	37-120	430-1395
<b>DP 2</b>	Two Stage	Natural Gas/Light Oil	40-80	55-183	45-150	523-1744
<b>DP 2 SP</b>	Two Stage	Natural Gas/Light Oil	40-80	70-220	58-180	674-2093



## Burner Dimensions

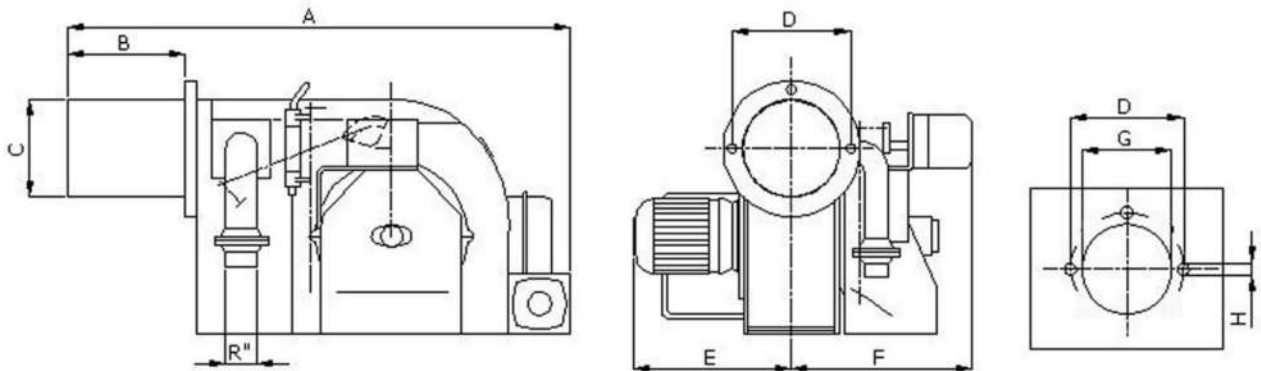

	A	B	C	D	E	F	G	H	R''
<b>DP 2 A</b>	1030	220	194	305	390	390	200	M12	2
<b>DP 2</b>	1030	220	194	305	420	390	200	M12	2
<b>DP 2 SP</b>	1100	220	219	305	420	390	225	M12	2 ½

Burner Equipment	DP 2 A	DP 2	DP 2 SP
Fan Motor	3 ~ 2.2 kW	3 ~ 3 kW	3 ~ 4 kW
Oil Pump Motor	3 ~ 1.1 kW	3 ~ 1.1 kW	3 ~ 1.1 kW
Servomotor	Conectron LKS 310	Conectron LKS 310	Conectron LKS 310
Control Unit	Satronic TMG 740	Satronic TMG 740	Satronic TMG 740
Oil Pump	Suntec AJ6AE	Suntec AJ6AE	Suntec E7NA
Ignition Transformer (Gas Fuel)	Brahma TB2S Electronic / 2×12 kV / 35 mA	Brahma TB2S Electronic / 2×12 kV / 35 mA	Brahma TB2S Electronic / 2×12 kV / 35 mA
Ignition Transformer (Oil Fuel)	Brahma TB2S Electronic / 2×12 kV / 35 mA	Brahma TB2S Electronic / 2×12 kV / 35 mA	Brahma TB2S Electronic / 2×12 kV / 35 mA
Gas Solenoid Valve (Fast Opening)	Dungs 2"	Dungs 2"	Dungs 2 ½"
Gas Solenoid Valve (Slow Opening)	Dungs 2"	Dungs 2"	Dungs 2 ½"
Oil Solenoid Valve	Rapa 1/8" (x2) & 1/4"	Rapa 1/8" (x2) & 1/4"	Rapa 1/8" (x2) & 1/4"
Gas Pressure Control	Gas pressure switch Dungs or Krom Schroder	Gas pressure switch Dungs or Krom Schroder	Gas pressure switch Dungs or Krom Schroder
Air Pressure Control	Air pressure switch Dungs or Krom Schroder	Air pressure switch Dungs or Krom Schroder	Air pressure switch Dungs or Krom Schroder
Flame Detector	Satronic UVZ 780	Satronic UVZ 780	Satronic UVZ 780
Burner Control Panel	✓ (separated)	✓ (separated)	✓ (separated)



## ALL THERM (GIBRALTAR) LTD

### HEADQUARTERS :

World Trade Center  
6 Bayside Road 1st Floor - Unit 1.02  
GX1 1AA Gibraltar  
☎ (+350) 200 60207  
✉ info@alltherm.group

### SALES MANAGER :

Javier *Martinez* Lesmes  
C/ López Bravo 7. Naves CAM 45  
09001 Burgos  
☎ (+34) 639 324 269  
✉ j.martinez@alltherm.group

