

# BURNERS



# ALL THERM

OIL, GAS AND DUAL: UP TO 5M KCAL/H  
THIRD WORLDWIDE INDUSTRIAL GROUP  
TUV INTERNATIONAL CERTIFICACION

**2 YEAR GUARANTY**



## DR 2



Burner Performance Chart

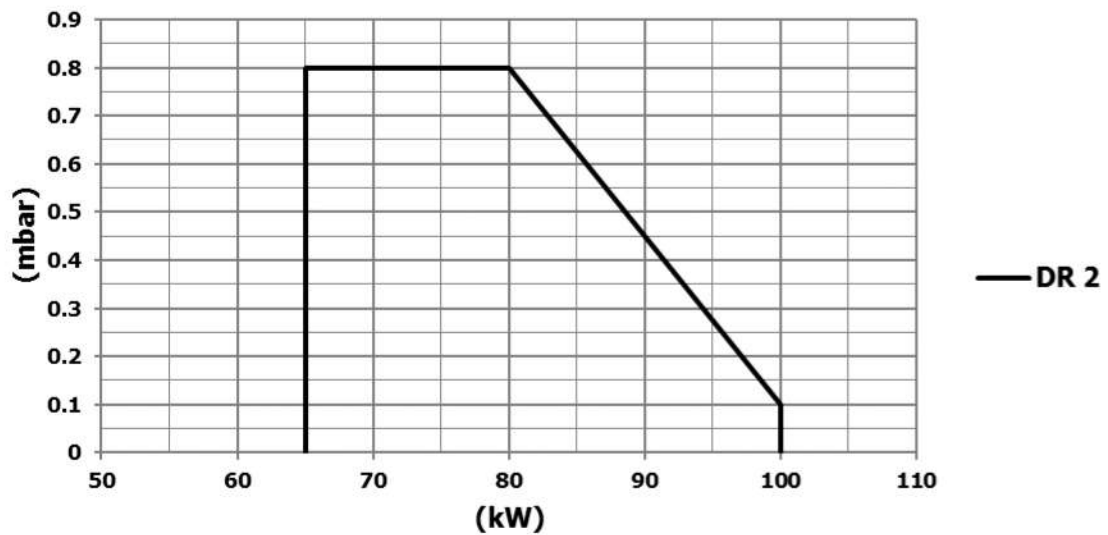

Function	Fuel	Gas Pressure mbar	Gas Consumption m <sup>3</sup> n/h	Oil Consumption kg/h	Heating Capacity kW
DR 2	Natural Gas/Light Oil	15-40	6.85-10.5	5.6-8.6	65-100



## Burner Dimensions

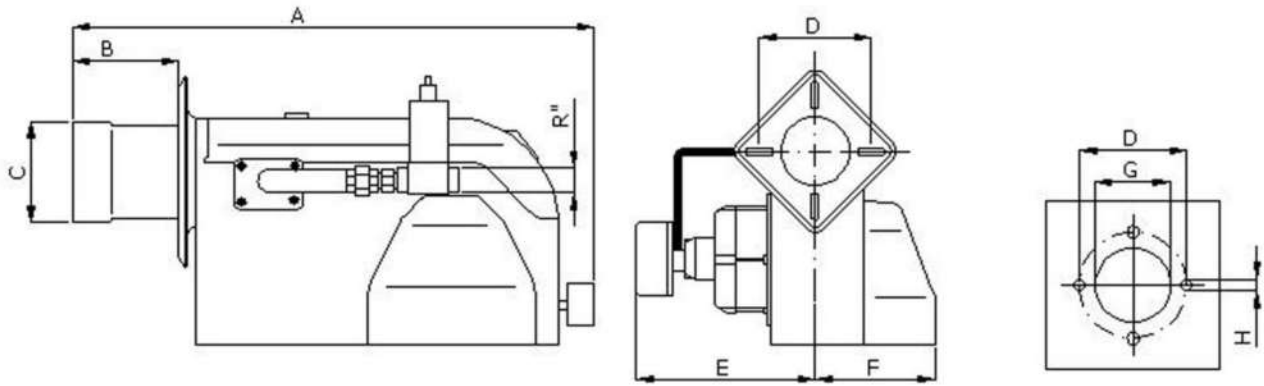

	A	B	C	D	E	F	G	H	R''
<b>DR 2</b>	517	97	88	120-165	184	240	90	M8	1/2

### Burner Equipment

### DR 2

Fan Motor	1 ~ 90 W
Control Unit	G 811
Oil Pump	Suntec AS47C
Ignition Transformer	Electronic / 2x7 kV / 35 mA
Gas Solenoid Valve (Slow Opening)	Dungs or Krom Schroder 1/2"
Oil Solenoid Valve	1/8" (With pump)
Gas Pressure Control	Gas pressure switch Dungs or Krom schroder
Air Pressure Control	Air pressure switch Dungs or Krom schroder
Flame Detector	Landis QRA2



## ALL THERM (GIBRALTAR) LTD

### HEADQUARTERS :

World Trade Center  
6 Bayside Road 1st Floor - Unit 1.02  
GX1 1AA Gibraltar  
☎ (+350) 200 60207  
✉ info@alltherm.group

### SALES MANAGER :

Javier *Martinez* Lesmes  
C/ López Bravo 7. Naves CAM 45  
09001 Burgos  
☎ (+34) 639 324 269  
✉ j.martinez@alltherm.group

