

BURNERS



ALL THERM

OIL, GAS AND DUAL: UP TO 5M KCAL/H
THIRD WORLDWIDE INDUSTRIAL GROUP
TUV INTERNATIONAL CERTIFICACION

2 YEAR GUARANTY



ID 3400 ID 4400 M



Burner Performance Chart

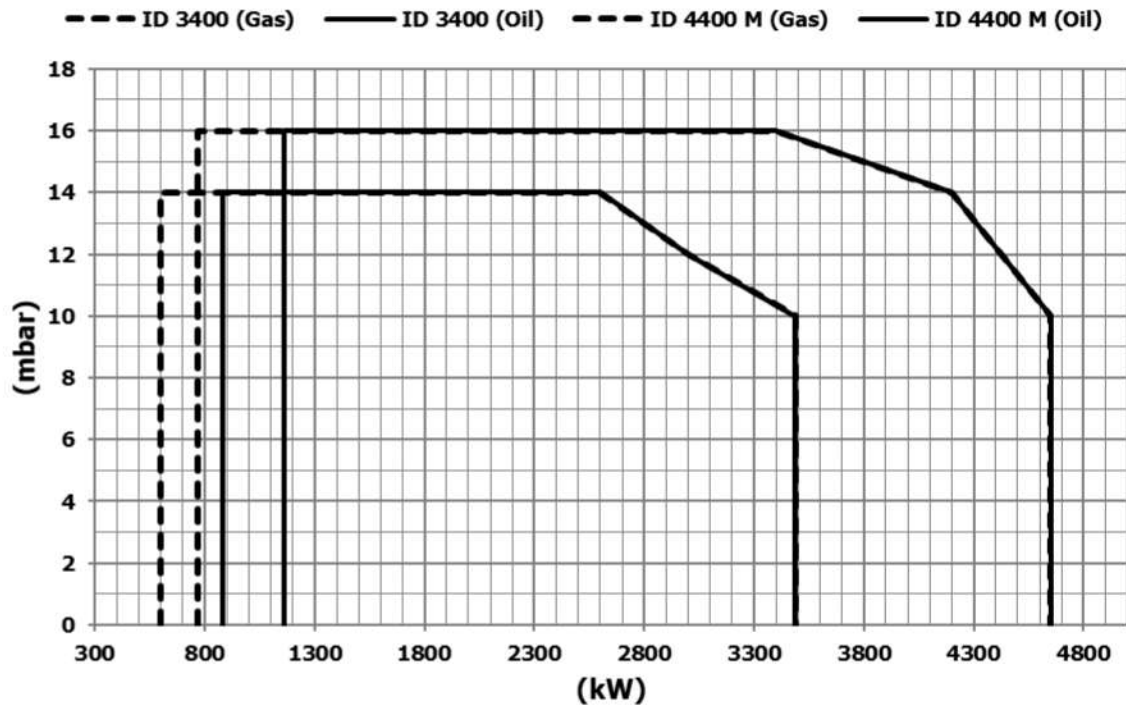

	Function	Fuel	Gas Pressure Mbar	Gas Consumption m ³ n/h	Light oil Consumption kg/h	Heating Capacity kW
ID 3400	Three Stage	Natural Gas/Light Oil	120-140	63-367	75.7-300	600-3488
ID 4400 M	Three Stage	Natural Gas/Light Oil	120-140	81-489	100-400	767-4651



Burner Dimensions

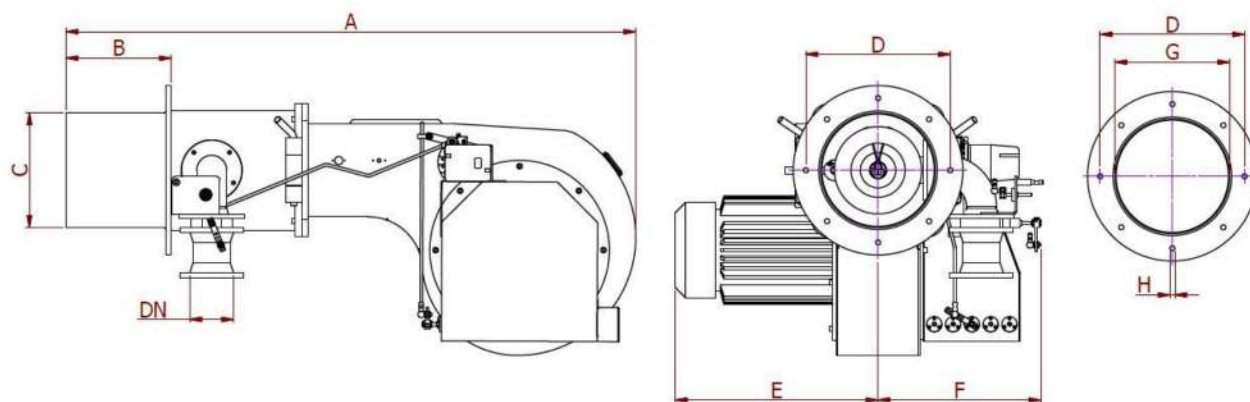

	A	B	C	D	E	F	G	H	DN
ID 3400	1697	303	311	430	604	484	330	M14	80
ID 4400 M	1697	303	341	430	604	484	360	M14	80

Burner Equipment	ID 3400	ID 4400 M
Fan Motor	3 ~ 7.5 kW	3 ~ 11 kW
Oil Pump Motor	3 ~ 1.5 kW	3 ~ 1.5 kW
Servomotor	Conectron LKS 310	Conectron LKS 310
Control Unit	Satronic TMG 740	Satronic TMG 740
Oil Pump	Suntec E7NA	Suntec TA2A
Ignition Transformer (Gas Fuel)	Brahma T8/G Induction / 2×6.5 kV / 35 mA	Brahma T8/G Induction / 2×6.5 kV / 35 mA
Ignition Transformer (Oil Fuel)	Brahma T8/G Induction / 2×6.5 kV / 35 mA	Brahma T8/G Induction / 2×6.5 kV / 35 mA
Gas Solenoid Valve (Fast Opening)	Dungs 2 ½" Fast opening	Dungs 3" Fast opening
Gas Solenoid Valve (Slow Opening)	Dungs 2 ½" Slow opening	Dungs 3" Slow opening
Gas Solenoid Valve (Pilot Valve)	Brahma ½" (S10) (x2)	Brahma ½" (S10) (x2)
Oil Solenoid Valve	Rapa ¼" SV04R2.5 Rapa ¼" BV01L2 (x3)	Rapa ¼" SV04R3 Rapa ¼" BV01L2 (x3)
Gas Pressure Control	Gas pressure switch Dungs or Krom schroder	Gas pressure switch Dungs or Krom Schroder
Air Pressure Control	Air pressure switch Dungs or Krom schroder	Air pressure switch Dungs or Krom schroder
Flame Detector	Satronic UVZ 780	Satronic UVZ 780
Push button	Dungs DKH ½" (x3)	Dungs DKH ½" (x3)
Tightness Control	Dungs VDK 200 A	Dungs VDK 200 A
Pressure Gauge	Dungs KP 80 0-100 mbar Dungs KP 80 0-250 mbar (x2)	Dungs KP 80 0-100 mbar Dungs KP 80 0-250 mbar (x2)
Filter	Dungs GF 40065/3 (2 ½")	Dungs GF 40080/3 (3")
Pressure Regulator	Dungs ½"	Dungs ½"
Burner Control Panel	✓ (separated)	✓ (separated)



ALL THERM (GIBRALTAR) LTD

HEADQUARTERS :

World Trade Center
6 Bayside Road 1st Floor - Unit 1.02
GX1 1AA Gibraltar
☎ (+350) 200 60207
✉ info@alltherm.group

SALES MANAGER :

Javier *Martinez* Lesmes
C/ López Bravo 7. Naves CAM 45
09001 Burgos
☎ (+34) 639 324 269
✉ j.martinez@alltherm.group

